

# LED 60W High Bay Industrial Lights



**Contains no mercury and lead free.**



Consumes 60% less energy compared to Fluorescent based Lights of similar brightness. Less energy means saving hundreds or even thousands of dollars over the life of the fixture, while help protecting the environment.



Solid State High Brightness LED offers more than 22.5 years (50,000+ hrs) of lifespan. This is about 10 times longer than average fluorescent lights.



Virtually maintenance free since no light bulb needs to be replaced. This is essential for fixture locations that are difficult to access.



Patented technology allows heat dissipation effectively from unit's body construction. No additional heat sink or fan required.



Extremely low operating temperature to ensure reliability and durability of the fixture. No overheating to worry about.



Instant full brightness. No delay in warming up to full brightness and will not burn out when being switched on and off frequently.

[www.abright.com](http://www.abright.com)

Ideal for large indoor industrial and commercial applications, including warehouses, manufacturing facilities, loading docks and etc.

  
L I G H T I N G

## Specifications:

Part Number :	HB60W55K (White) HB60W35K (Warm White)	
Body material :	Patented Aluminum Alloy	
LED Source :	Multiple LED Package (60 W).	
Power :	60 watt	
Luminous Efficacy :	75 ~ 80 lumens per watt	
Color Temperature:	White	5,500K ± 500
	Warm White	3,500K ± 500
LED Rated Life :	50,000+ hours	
Voltage :	110V - 240V AC	
Operating Voltage :	24V DC	
Net Weight :	9.5 lb	

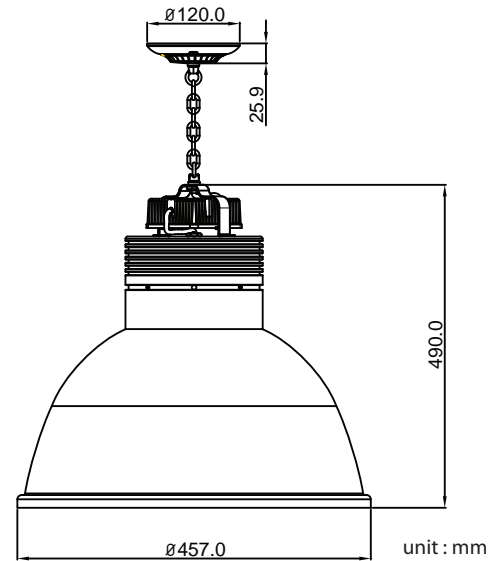

\*\*\* Specifications subject to change without further notice. \*\*\*

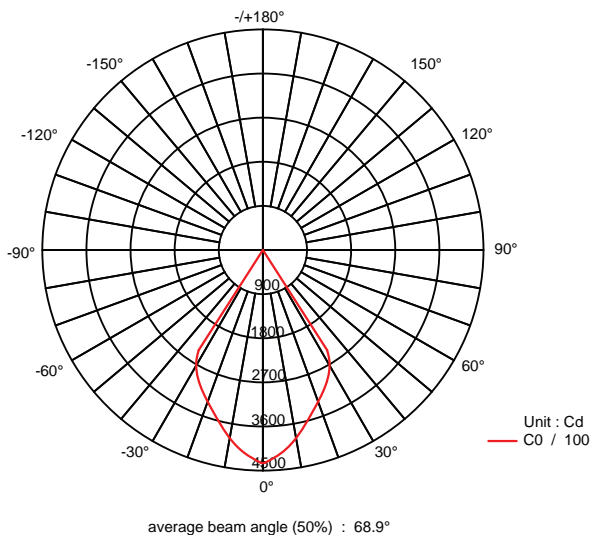

Luminous flux : 2222 lm

1.0 M	1026.35 lx	166.04cm
1.5 M	456.16 lx	249.06cm
2.0 M	256.59 lx	332.09cm
2.5 M	164.22 lx	415.11cm
3.0 M	114.04 lx	498.13cm
height	max	Beam Angle : 79.4°
		Dia

[www.abright.com](http://www.abright.com)

U.S. office :  
4214 Silver Peak Parkway,  
Suwanee, Georgia 30024  
Tel : 678-482-0789  
Fax : 678-482-2148

China factory :  
26 Building, XiTian 3rd Industrial Zone,  
GongMing Town, Shenzhen, China  
Tel : +86-755-27151735  
Fax : +86-755-81735353

**aBright**  
LIGHTING